



Ball Valves PN 20/50 (Class 150/300) AIT & IIT Construction (Carbon Steel and Stainless Steel)

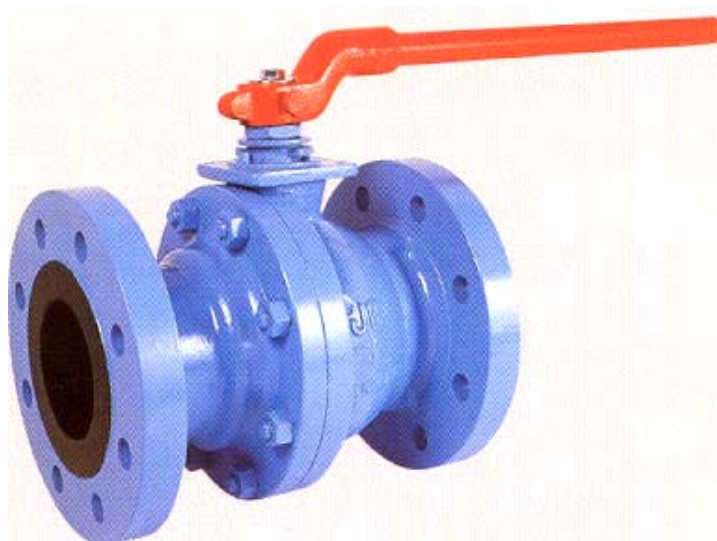

Fig. 515/530

API 6D and Fire Safe



Certificado No: 108856



LICENSE NO. 6D-0197



Certificate No: 121493

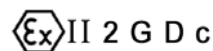



Ball Valves PN 20/50 (Class 150/300)

DN 15 - 200 (½" – 8") PN 20 (Class 150)
DN 15 - 150 (½" – 6") PN 50 (Class 300)
Parts and materials

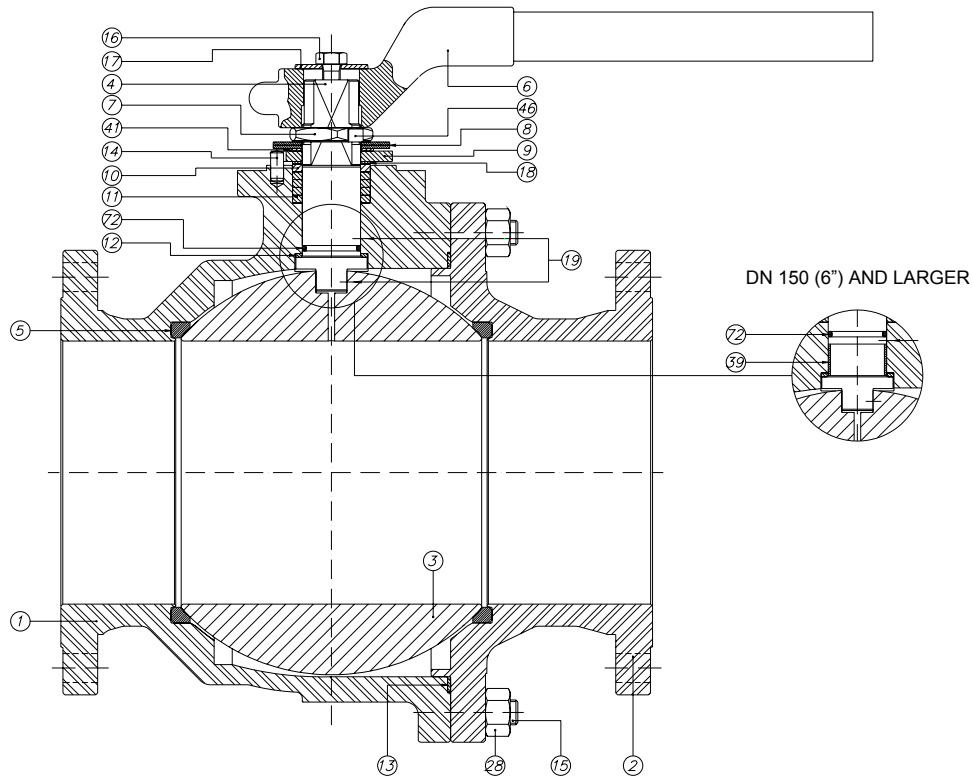

Item	Description	Material	
		AIT	IIT
1	Body	A 216 Gr. WCB (C ≤ 0,25%)	A 351 Gr. CF8M
2	Body connector	A 216 Gr. WCB (C ≤ 0,25%)	A 351 Gr. CF8M
3	Ball	A 351 Gr. CF8M (DN 15 : 25 A 479 Tp.316)	
4	Stem	A 479 Tp.316	
5	Seat ring	PTFE	
6	Wrench	Nodular Iron	
7	Gland nut	Zinc plated carbon steel	AISI 303
8	Disk spring	Carbon St.	EN.P. Carbon St.
9	Stop plate	Carbon St.	AISI 304
10	Gland	AISI 303	AISI 316
11	Gland packing	Graphite	
12	Stem thrust seal	25% G.F. PTFE	
13	Body connector seal	AISI 316L + Graphite	
14	Stop pin	Carbon St.	Stainless St.
15	Stud (DN 15 Bolt)	A 193 Gr. B7M	A 193 Gr. B8M
16	Bolt	DIN 933 5.6 Zinc plated	DIN 933 A2
17	Washer	Zinc plated carbon steel	AISI 304
18	Thrust washer	25% G.F. PTFE	
19	Antistatic device	Stainless St.	
28	Nut (DN 20 to 200)	A 194 Gr. 2HM	A 194 Gr. 8M
39	Stem bushing	STANSIT	
41	Spacer (DN 40 to 200)	Carbon St.	AISI 304
46	Washer	AISI-304	AISI 304
72	"O" Ring	FKM	
89	Identification plate	Stainless St.	



Ball Valves PN 20/50 (Class 150/300)

DN 15 - 200 (½" – 8") PN 20 (Class 150)

DN 15 - 150 (½" – 6") PN 50 (Class 300)

Dimensions

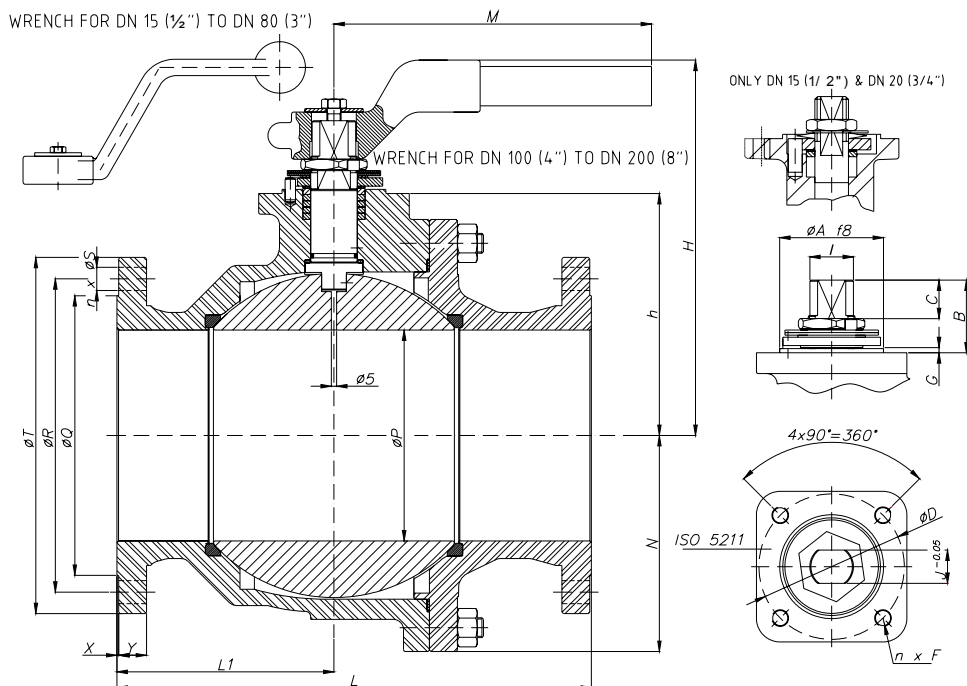

Series 515 (Class 150)

DN	ØP	L	L1	ØQ	ØR	n x ØS	ØT	X	Y	h	N	H	M	WEIGHT
15 (½")	15	108	47	34,9	60,3	4x15,9	88,9	1,6	9,5	46	---	112	166	2
20 (¾")	20	117	50	42,9	69,8	4x15,9	98,4	1,6	11,1	53	---	120,8	166	3
25 (1")	25	127	52	50,8	79,4	4x15,9	108	1,6	12,7	58	---	132	166	3,5
40 (1½")	40	165	65	73	98,4	4x15,9	127	1,6	15,9	76	---	193,3	213,7	8
50 (2")	50	178	68,5	92	120,6	4x19	152	1,6	17,5	83,5	---	201	213,7	11
65 (2½")	65	190	75	104,8	139,7	4x19	177,8	1,6	20,6	97	---	220	350	16
80 (3")	80	203	90	127	152,4	4x19	191	1,6	22,2	111	---	234,8	450	23
100 (4")	100	229	102	157,2	190,5	8x19	229	1,6	22,2	133	120	226,6	465	38
150 (6")	151	394	160	216	241,3	8x22,2	279,5	1,6	23,8	183	168	297	774	88
200 (8")	203	457	209	270	298,4	8x22,2	343	1,6	27	233	208	308	845	155

(*) Dimensions in mm and weight in kg.

Series 530 (Class 300)

DN	ØP	L	L1	ØQ	ØR	n x ØS	ØT	X	Y	h	N	H	M	WEIGHT
15 (½")	15	140	60	34,9	66,7	4x15,9	95,2	1,6	12,7	46	---	112	166	3
20 (¾")	20	152	65	42,9	82,5	4x19	117,5	1,6	14,3	53	---	120,8	166	4
25 (1")	25	165	70	50,8	88,9	4x19	123,8	1,6	15,9	58	---	132	166	5
40 (1½")	40	190	80	73	114,3	4x22,2	155,6	1,6	19	76	---	193,3	213,7	11
50 (2")	50	216	87	92	127	8x19	165,1	1,6	20,6	83,5	---	201	213,7	14
80 (3")	80	283	118	127	168,3	8x22,2	210,5	1,6	26,9	111	---	234,8	450	32
100 (4")	100	305	130	157,2	200	8x22,2	254	1,6	30,2	133	120	226,6	465	52
150 (6")	151	403	160	216	269,9	12x22,2	317,5	1,6	35	183	168	297	774	94

(*) Dimensions in mm and weight in kg.

Actuator connection

DN	ISO 5211	ØA	B	C	ØD	n x F	G	I	J
15 (½")	F05	35	11,5	5,7	50	4x M6	1,5	M12x1.5	9
20 (¾")	F05	35	15	7,4	50	4x M6	1,5	M12x1.5	9
25 (1")	F05	35	24	10,2	50	4x M6	1,5	M12x1.5	9
40 (1½")	F07	55	39,5	16,7	70	4x M8	3	M18x1.5	13
50 (2")	F07	55	41,5	17,6	70	4x M8	3	M18x1.5	13
65 (2½")	F07	55	44	18,1	70	4x M8	3	M22x1.5	16
80 (3")	F10	70	44,5	18,7	102	4x M10	3	M25x1.5	18
100 (4")	F10	70	56,5	28,7	102	4x M10	3	M28x1.5	20
150 (6")	F12	85	68	38,5	125	4x M12	3	M40x1.5	29
200 (8")	F14	100	70	37	140	4x M16	4	M45x2	32

(*) Dimensions in mm



Ball Valves PN 20/50 (Class 150/300)

DN 15 - 200 (½" – 8") PN 20 (Class 150)

DN 15 - 150 (½" – 6") PN 50 (Class 300)

General Characteristics, Torque&KV, P&T Rating

GENERAL CHARACTERISTICS	Fig.515/530 Series SFF	Split Body	Floating Ball	Full Bore
DESIGN STANDARDS				
Valves design	API 6D	ASME B16.34	BS 5351	NF E 29-470
Body design	ASME VIII Div.1			
Shell thickness	ASME B16.34	BS 5351		
Flanges	ASME B16.5 Raised face			
Face to face dimensions	ASME B16.10 Long pattern	API 6D	EN 558-2 Series 3, 4 & 12	
Actuator mounting flange	ISO 5211			
Wetted parts materials and bolting	NACE MR.01.75			
Shell finishing quality	MSS SP 55			
Marking	API 6D	BS 5351	NF E 29-470	CE - PED
				EN 19
TESTS AND CERTIFICATES				
Quality Assurance	ISO 9001	API Q1	CE - PED	
Fire Safe certification	BS 6755 Part 2	API 6FA	ISO 10497	API 607 4 TH Edition
Pressure testing	API 598	BS 6755 Part 1	ISO 5208	NF E 29-203
				EN 12266
Other	ISO 14001	ATEX		

Torque Values in Nm

VALVE SIZE	AT DIFFERENTIAL PRESSURE		VALVE SIZE	AT DIFFERENTIAL PRESSURE	
	Class 150	Class 300		Class 150	Class 300
	20 bar	50 bar		20 bar	50 bar
DN 15 (½")	8	12	DN 65 (2½")	60	
DN 20 (¾")	10	16	DN 80 (3")	90	150
DN 25 (1")	15	20	DN 100 (4")	150	230
DN 40 (1½")	25	35	DN 150 (6")	250	342
DN 50 (2")	40	55	DN 200 (8")	700	

Kv Values in m³/h

DN 15 (½")	DN 20 (¾")	DN 25 (1")	DN 40 (1½")	DN 50 (2")
20	40	75	170	270
DN 65 (2½")	DN 80 (3")	DN 100 (4")	DN 150 (6")	DN 200 (8")
550	1000	1650	4200	9000

Pressure-Temperature

For A216 Gr. WCB only. For other materials consult ASME B16.34

