



Ball Valves PN 100 (Class 600) IIN Construction (Stainless Steel)

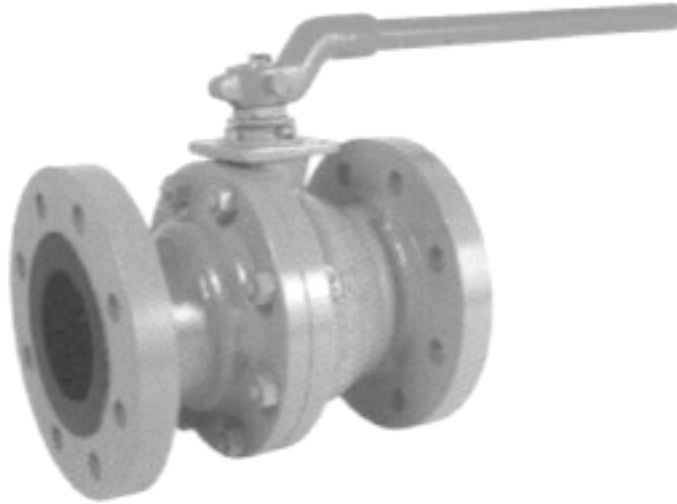

Fig. 660 IIN

API 6D and Fire Safe



Certificado No: 108856



LICENSE NO. 6D-0197



Certificate No: 121493

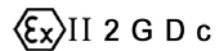



Ball Valves PN 100 (Class 600)

DN 50 - 100 (2" – 4")

Parts and materials

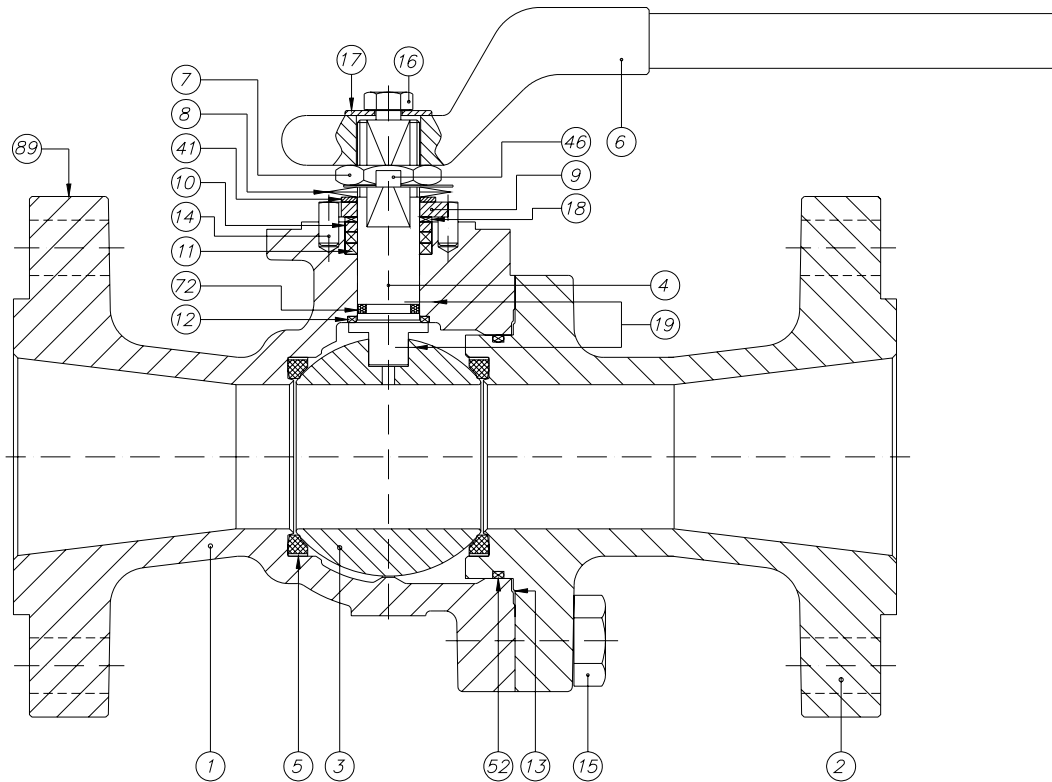

Item	Description	Material
1	Body	A 351 Gr. CF8M
2	Body connector	A 351 Gr. CF8M
3	Ball	A 351 Gr. CF8M
4	Stem	A 479 Tp.316
5	Seat ring	Nylon
6	Wrench	Nodular iron
7	Gland nut	AISI 303
8	Disk spring	E.N.P. Carbon steel
9	Stop plate	AISI 304
10	Gland	AISI 316
11	Gland packing	Graphite
12	Stem thrust seal	25% G.F. PTFE
13	Body connector	AISI 316L + Graphite
14	Stop pin	Stainless steel
15	Bolt	A 193 Gr. B8M
16	Bolt	DIN 933 A2
17	Washer	AISI 304
18	Thrust washer	25% G.F. PTFE
19	Antistatic device	Stainless steel
41	Spacer	AISI 304
46	Locking washer	AISI 304
52	"O" Ring	FKM
72	"O" Ring	FKM
89	Identification plate	Stainless steel



Ball Valves PN 100 (Class 600)

DN 50 - 100 (2" – 4")

Dimensions

WRENCH FOR DN 50 (2") & DN 80 (3")

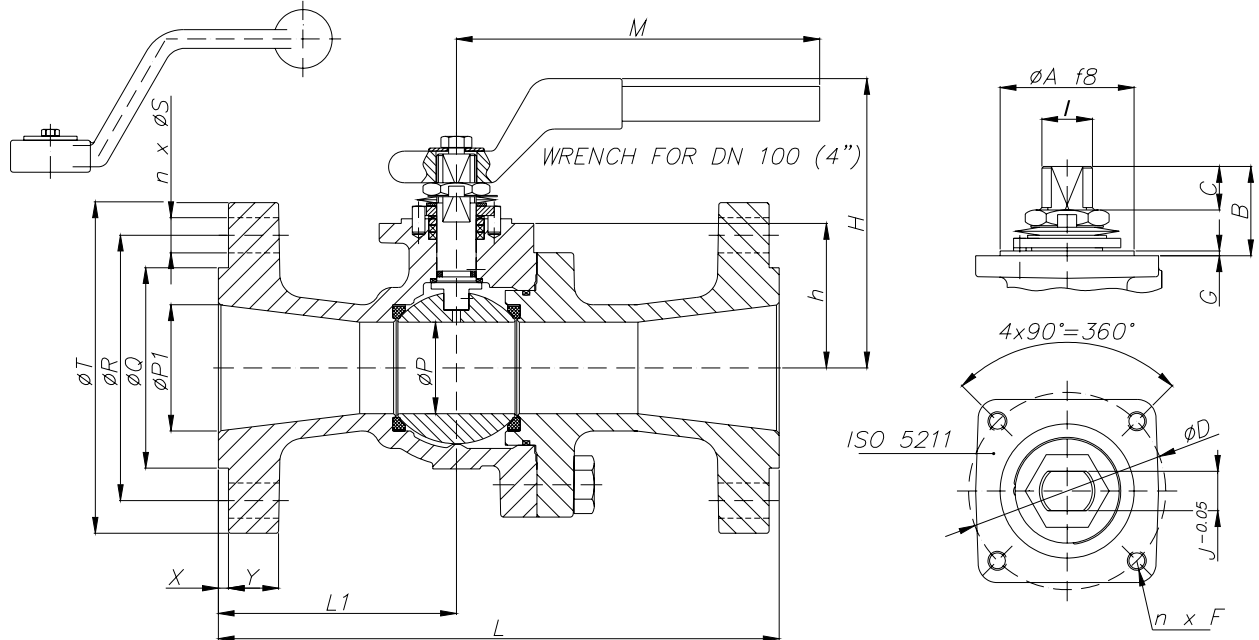

Valve with wrench

DN	ØP1	ØP	L	L1	ØQ	ØR	n x ØS	ØT	X	Y	h	M	H	WEIGHT
50 (2")	50	40	292	120	92	127	8x19	165	6,4	25,4	65,5	350	156	17
80 (3")	79,6	58	356	151	127	168,3	8x22,2	209,5	6,4	31,8	91,5	450	183,3	30
100 (4")	100	80	432	190	157	215,9	8x25,4	273	6,4	38,1	122	715	211,5	64

(* Dimensions in mm and weight in kg.

Actuator connection

DN	ISO 5211	ØA	B	C	ØD	n x F	G	I	J
50 (2")	F07	55	43	17,7	70	4xM8	3	M22x1.5	16
80 (3")	F10	70	44	17,4	102	4xM10	3	M25x1.5	18
100 (4")	F12	85	55,5	26,7	125	4xM12	3	M35x2	25

(* Dimensions in mm and weight in kg.



Ball Valves PN 100 (Class 600)

DN 50 - 100 (2" – 4")

General Characteristics, Torque&KV, P&T Rating

GENERAL CHARACTERISTICS	Fig.660, Series SFR	S plit Body	F loating Ball	R educed Bore	
DESIGN STANDARDS					
Valves design	API 6D	ASME B16.34	BS 5351	NF E 29-470	
Body design	ASME VIII Div.1				
Shell thickness	ASME B16.34	BS 5351			
Flanges	ASME B16.5 Raised face				
Face to face dimensions	ASME B16.10 Long pattern	API 6D	EN 558-2 Series 5		
Actuator mounting flange	ISO 5211				
Wetted parts materials and bolting	NACE MR.01.75				
Shell finishing quality	MSS SP 55				
Marking	API 6D	BS 5351	NF E 29-470	CE - PED	EN 19
TESTS AND CERTIFICATES					
Quality Assurance	ISO 9001	API Q1	CE - PED		
Fire Safe certification	BS 6755 Part 2	API 6FA	ISO 10497		
Pressure testing	API 598	BS 6755 Part 1	ISO 5208	NF E 29-203	EN 12266
Other	ISO 14001	ATEX			

Torque Values in Nm

VALVE SIZE	AT DIFFERENTIAL PRESSURE	
	Class 600 100 bar	
DN 50 (2")	95	
DN 80 (3")	185	
DN 100 (4")	325	

Kv Values in m³/h

DN 50 (2")	DN 80 (3")	DN 100 (4")
140	300	600

Pressure-Temperature

For A351 Gr. CF8M only. For other materials consult ASME B16.34

P Bar PN 100 (Class 600)

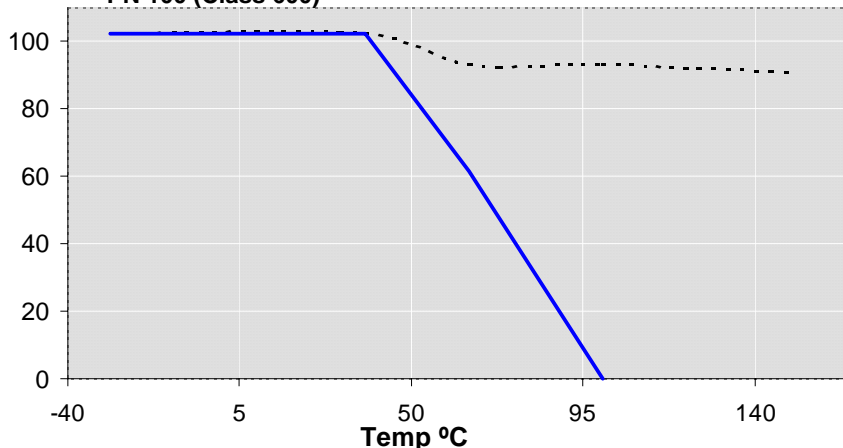

NYLON SEATS

— 2" to 4"