



Forged Gate Valves
Fig. CF 150 - Class 150
Size ½" – 2" (DN 15 – 50)



FIG. CF 150

GATE VALVE

API 602, BS 5352 & ASME B16.34

Connections according to:

ASME B16.5

ASME B16.25



Forged Gate Valves

Fig. CF 150 - Class 150

Parts and Materials

Parts and materials

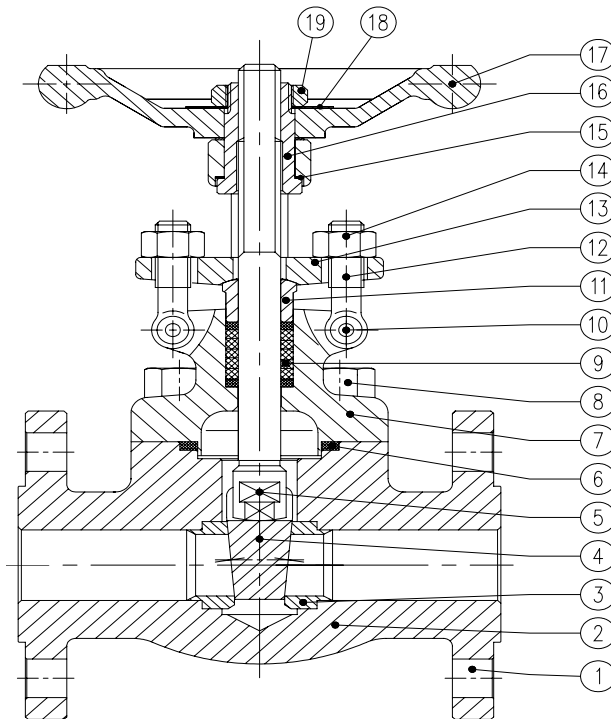

Item	Description	Material	
		Carbon Steel	Stainless Steel
1	Welding flange	A 105	A 182 F316L
2	Body	A 105	A 182 F316L
3	Seat	A 182 F6A + STL	A 182 F316L + STL
4	Wedge	A 182 F6A	A 182 F316L
5	Stem	AISI 410	A 182 F316L
6	Gasket	AISI 304 + Graphite	AISI 316 + Graphite
7	Bonnet	A 105	A 182 F316L
8	Bolt	A 193 B7	A 193 B8M
9	Packing	Flexible Graphite and steels steel w ire braided	
10	Pin	AISI 410	AISI 316L
11	Packing Gland	AISI 410	AISI 316L
12	Eye Bolt	A 193 B7	A 193 B8M
13	Gland Flange	A 105	A 182 F316L
14	Nut	A 194 2H	A 194 8M
15	Washer	AISI 410	
16	Yoke Nut	AISI 410	
17	Handw heel	Ductile iron	
18	Nameplate	304SS	
19	Hex Nut	1035 Zinc Plated	



Forged Gate Valves

Fig. CF 150 - Class 150

Dimensions

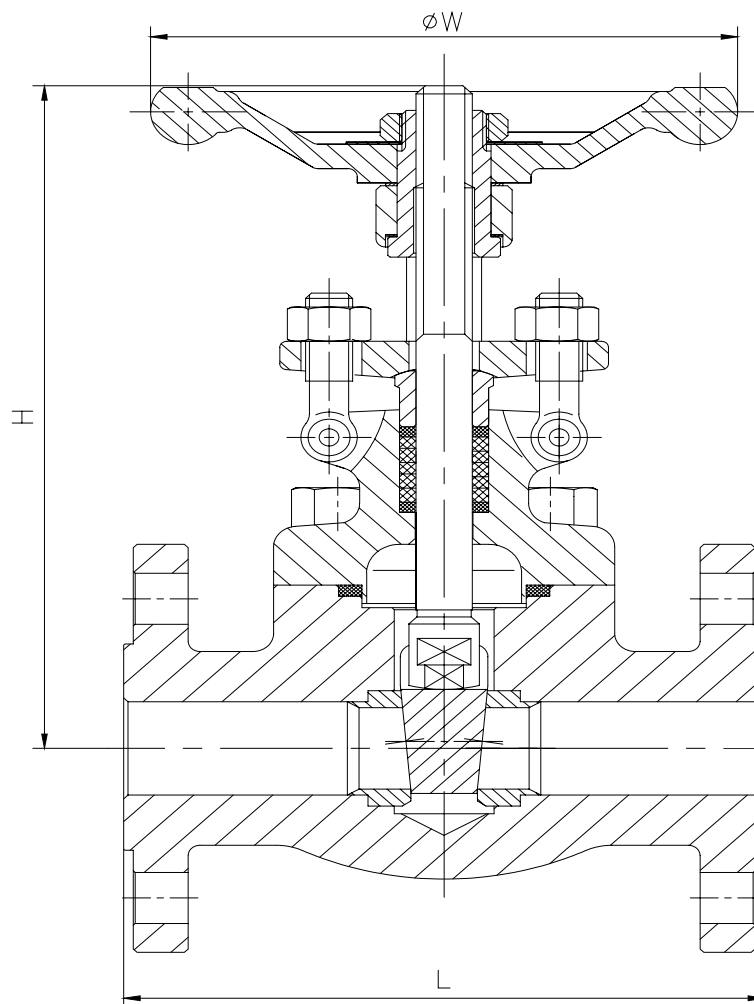

Dimensions

SIZE	L	H	øW	WT
½" (DN 15)	108	166	100	4.5
¾" (DN 20)	117	169	100	5.2
1" (DN 25)	127	193	125	8.2
1¼" (DN 32)	140	230	160	11.5
1½" (DN 40)	165	246	160	12.5
2" (DN 50)	178	283	180	20.3

(*) Dimensions in mm.



Forged Gate Valves

Fig. CF 150 - Class 150

General Characteristics, P&T Rating

GENERAL CHARACTERISTICS	Forged Gate Valve		
DESIGN STANDARDS			
Valves design	API 602	ASME B 16.34	BS 5352
Connections	ASME B16.5	ASME B16.25	
Face to face dimensions	ASME B16.10		
TESTS AND CERTIFICATES	API 598		
Quality Assurance	ISO 9001		
Pressure testing	EN 12266-1		
Marking	EN 19		

Pressure-Temperature

