



# Gate Valves Type Bolted Bonnet

## Class 300 DN 50-600 (2" – 24")

### Carbon, Alloy and Stainless Steel



## Fig. VC300BB

Design:

API 600 & ISO 10434

ASME B16.34 and BS1414





# Gate Valves Class 300

## Type Bolted Bonnet

### Parts and materials

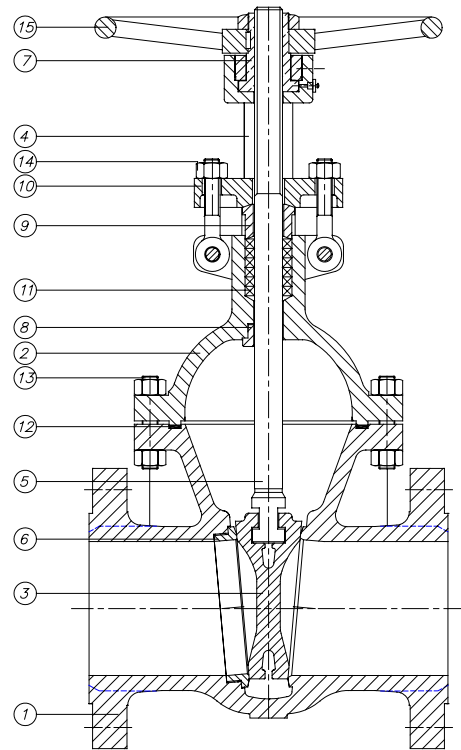

#### Trim Material

API 600 Trim No.	Stem / Backseat	Seating Surface Body / Wedge
1	13% Cr	13% Cr
2	SS 304	SS 304
3	SS310	SS310
4	13% Cr	13% Cr (Hard)
5 or 5A	13% Cr	HF
6	13% Cr	13% Cr / Cu Ni
7	13% Cr	13% Cr / 13% Cr (Hard)
8 or 8A	13% Cr	HF / 13% Cr
9	Monel	Monel
10	SS 316	SS 316
11 or 11A	Monel	HF / Monel
12 or 12A	SS 316	HF / SS 316
13	Alloy 20	Alloy 20
14 or 14A	Alloy 20	HF / Alloy 20

*HF: Hard Facing using Co Cr welding alloy (Stellite)*

Item	Description	Material			
		Carbon Steel	Carbon Steel (Low Temp.)	Alloy Steel	Stainless Steel
1	Body	A 216 Gr.WCB	A 352 Gr.LCB	A 217 Gr.C5	A 351 Gr.CF8M
2	Bonnet	A 216 Gr.WCB	A 352 Gr.LCB	A 217 Gr.C5	A 351 Gr.CF8M
3	Gate	A 216 Gr.WCB + ER410	A 352 Gr.LCB + ER308	A 217 Gr.C5 + ER410	A 351 Gr.CF8M
4	Yoke	A 216 Gr.WCB	A 352 Gr.LCB	A 217 Gr.C5	A 351 Gr.CF8M
5	Stem	A 182 Gr.F6a	A 182 Gr.F304	A 182 Gr.F6a	A 182 Gr.F316
6	Seat Ring	A 105 + Stellite	A 182 Gr.F304	A 182 Gr.F6a + Stellite	----
7	Stem Nut	B 148 / A 439 Gr.D2	B 148 / A 439 Gr.D2	B 148 / A 439 Gr.D2	B 148 / A 439 Gr.D2
8	Backseat	A182 Gr.F6a	A182 Gr. F304	A 182 Gr.F6a	----
9	Gland	A 105	A 105	A 182 Gr.F6a	A 182 Gr.F316
10	Gland Flanged	A 105	A 105	A 105	A 182 Gr.F304
11	Stem Packing	Graphited	Graphited	Graphited	Graphited
12	Gasket	SPW SS304 / Graphited	SPW SS304 / Graphited	SPW SS304 / Graphited	SPW SS316 / Graphited
13	Bonnet Bolt & Nut	A 193 Gr.B7 / A 194 Gr.2H	A 193 Gr.B7 / A 194 Gr.2H	A 193 Gr.B7 / A 194 Gr.2H	A 193 Gr.B7 / A 194 Gr.2H
14	Eye Bolt & Nut	A 193 Gr.B7 / A 194 Gr.2H	A 193 Gr.B7 / A 194 Gr.2H	A 193 Gr.B7 / A 194 Gr.2H	A 193 Gr.B7 / A 194 Gr.2H
15	Handw heel	Carbon Steel	Carbon Steel	Carbon Steel	Carbon Steel

*Item 6 and 8 only in Carbon Steel and Alloy Steel construction*



# Gate Valves Class 300

## Type Bolted Bonnet

### Dimensions

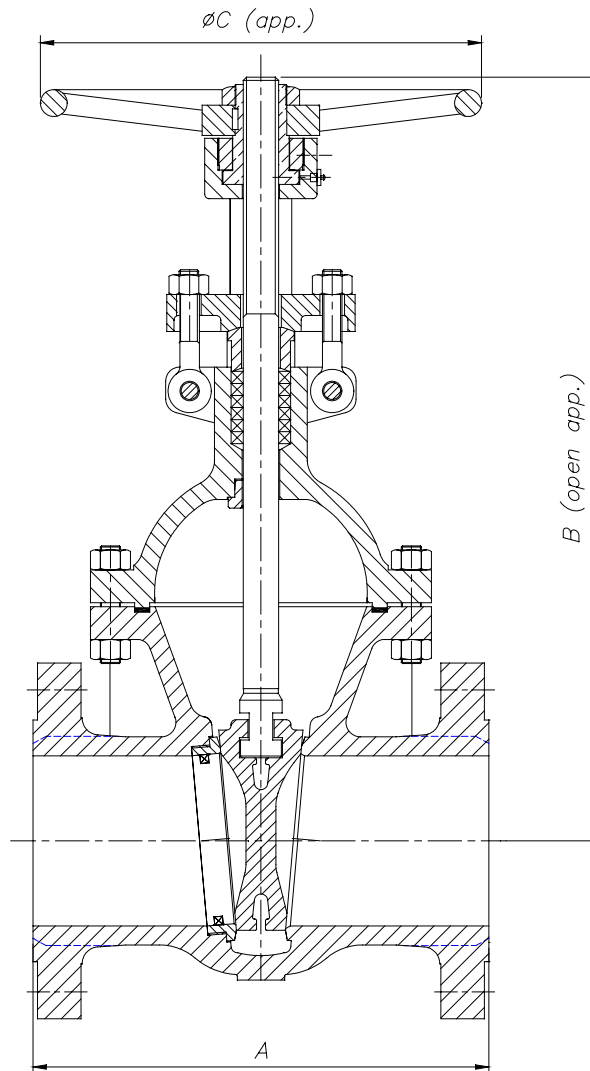

DN	A (RF/BW)	B	ØC	WEIGHT
50 (2")	216	410	200	32
65 (2½")	241	450	250	35
80 (3")	282,5	485	250	55
100 (4")	305	615	300	80
125 (5")	381	725	350	100
150 (6")	403	835	350	150
200 (8")	419	1015	450	225
250 (10")	457	1230	500	350
300 (12")	502	1555	500	480
350 (14")	762	1720	600	745
400 (16")	838	1970	600	1060
450 (18")	914	2160	680	1325
500 (20")	991	2410	760	1725
550 (22")	1092	2550	760	1900
600 (24")	1143	2810	760	2570

(\*) Dimensions in mm and weight in kg.



# Gate Valves Class 300

## Type Bolted Bonnet

### General Characteristics, Cv, P&T Rating

GENERAL CHARACTERISTICS		Fig. VC300BB		
<b>DESIGN STANDARDS</b>				
Valves design	API 600 & ISO 10434	ASME B16.34	BS 1414	
End to End Dimensions	ASME B16.10 & ISO 5752			
Flanged Dimensions	ASME B16.5 & ISO 7005-1 Part. 1	ASME B16.47	BS 3293	MSS SP-44
Buttweld Dimensions	ASME B16.25			
Visual Inspection	MSS SP- 55			
Marking	MSS SP-25 & ISO 5209			
<b>TESTS AND CERTIFICATES</b>				
Pressure testing	API 598 & ISO 5208	BS 6755 Part. 1	MSS SP-61	

#### Cv Values in U.S. Gallons/min.

DN	Cv	DN	Cv
50 (2")	250	300 (12")	12050
65 (2½")	450	350 (14")	15100
80 (3")	620	400 (16")	20300
100 (4")	1160	450 (18")	25000
125 (5")	1900	500 (20")	32500
150 (6")	2700	550 (22")	40000
200 (8")	5100	600 (24")	48500
250 (10")	8050		

#### Pressure-Temperature (STANDARD CLASS According ASME B16.34)

Temp °C	MATERIAL			
	A216 WCB Bar	A352 LCB Bar	A217 C5 Bar	A351 CF8M Bar
-29 to 38	51,0	47,9	51,7	49,6
95	46,5	45,1	51,3	42,7
150	45,1	44,1	49,3	38,6
205	43,8	42,7	48,6	35,5
260	41,3	40,3	45,8	33,1
315	37,9	36,9	41,7	31,0
345	36,9	36,2	40,7	30,7
375	36,9		39,3	29,6
400	34,8		36,5	29,3
425	28,2		35,1	28,9
450	18,6		33,4	28,9
485	11,7		25,5	28,6
510	7,2		18,9	26,5
540	3,4		13,8	24,1
565			10,0 *	23,8 *
595			6,9 *	21,0 *
620			4,1 *	16,2 *
650			2,4 *	12,7 *
675				10,0 *
705				7,9 *
735				6,5 *
760				5,2 *
790				4,1 *
815				2,8 *

\* FOR WELD END VALVES ONLY. FLANGED END RATINGS TERMINATE AT 540°C