



**Swing Check Valves Type Pressure Seal**  
**Class 900 DN 50-500 (2" – 20")**  
 Carbon, Alloy and Stainless Steel



# Fig. VR900PS

**Design:**  
**BS 1868 & API 6D**  
**ASME B16.34**





# Swing Check Valves Class 900

## Type Pressure Seal

### Parts and materials

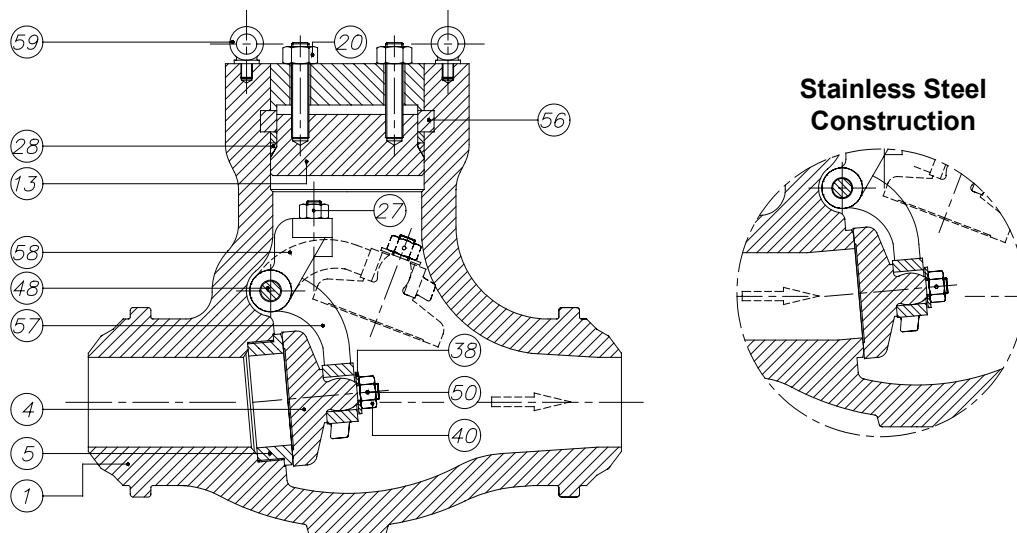

#### Trim Material

API 600 Trim No.	Stem / Backseat	Seating Surface Body / Wedge
1	13% Cr	13% Cr
2	SS 304	SS 304
3	SS310	SS310
4	13% Cr	13% Cr (Hard)
5 or 5A	13% Cr	HF
6	13% Cr	13% Cr / Cu Ni
7	13% Cr	13% Cr / 13% Cr (Hard)
8 or 8A	13% Cr	HF / 13% Cr
9	Monel	Monel
10	SS 316	SS 316
11 or 11A	Monel	HF / Monel
12 or 12A	SS 316	HF / SS 316
13	Alloy 20	Alloy 20
14 or 14A	Alloy 20	HF / Alloy 20

**HF: Hard Facing using Co Cr welding alloy (Stellite)**

Item	Description	Material			
		Carbon Steel	Carbon Steel (Low Temp.)	Alloy Steel	Stainless Steel
1	Body	A 216 Gr.WCB	A 352 Gr.LCB	A 217 Gr.C5	A 351 Gr.CF8M
4	Disc	A 105 + Stellite	A 352 Gr.LCB + Stellite	A 182 Gr.F6a + Stellite	A 182 Gr.F316 + Stellite
5	Seat Ring	A 105 + Stellite	A182 Gr.F304 + Stellite	A 182 Gr.F6a + Stellite	A 182 Gr.F316 + Stellite
13	Cover	A 216 Gr.WCB / A 515 Gr.70	A 352 Gr.LCB	A 217 Gr.C5	A 351 Gr.CF8M
20	Cover Bolt & Nut	A 193 Gr.B7 / A 194 Gr.2H	A 193 Gr.B7 / A 194 Gr.2H	A 193 Gr.B7 / A 194 Gr.2H	A 193 Gr.B7 / A 194 Gr.2H
27	Bracket Stud & Nut	A 193 Gr.B8 / A 194 Gr.8	A 193 Gr.B8 / A 194 Gr.8	A 193 Gr.B8 / A 194 Gr.8	A 193 Gr.B8M / A 194 Gr.8M
28	Gasket	A182 Gr.F304	A182 Gr.F304	A182 Gr.F304	A182 Gr.F316
38	Washer	AISI 410	AISI 304	AISI 410	AISI 316
40	Disc Nut	AISI 304	AISI 304	AISI 304	AISI 316
48	Hinge Pin *	A182 Gr.F6a	A182 Gr.F304	A182 Gr.F6a	A 182 Gr.F316
50	Split Pin	AISI 304	AISI 304	AISI 304	AISI 316
56	Segmental Ring	A 105	A182 Gr.F304	A182 Gr.F6a	A182 Gr.F316
57	Hinge	A 216 Gr.WCB / A 515 Gr.70	A 352 Gr.LCB	A 217 Gr.C5	A 351 Gr.CF8M
58	Hinge Bracket	A 216 Gr.WCB / A 515 Gr.70	A 352 Gr.LCB	A 217 Gr.C5	A 351 Gr.CF8M
59	Lifting Hook	A105	A105	A105	A105

Item 5 only in Carbon Steel and Alloy Steel construction

\* It's also manufactured with Hinge Pin passing through Body with Plug



# Swing Check Valves Class 900

## Type Pressure Seal

### Dimensions

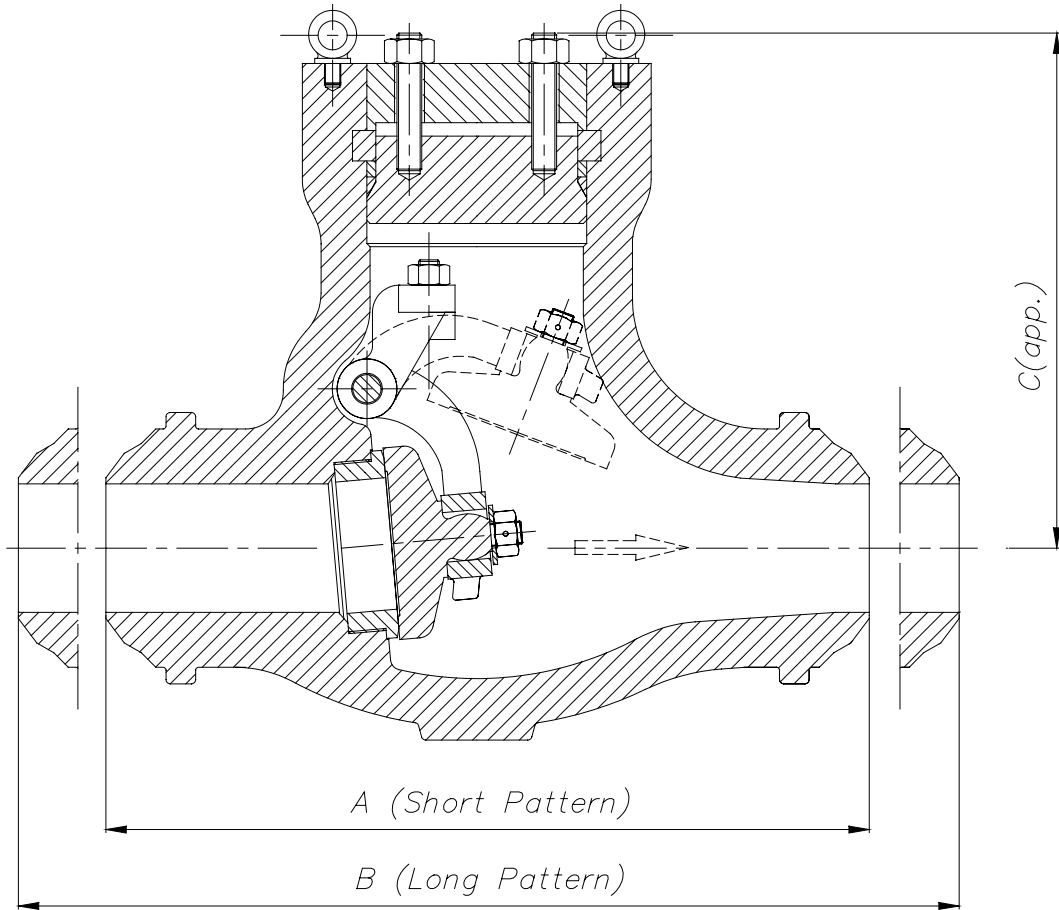

DN	A	B	C	WEIGHT
50 (2")	216	368	240	43
65 (2½")	254	419	265	55
80 (3")	305	381	280	72
100 (4")	356	457	350	80
125 (5")	432	559	410	108
150 (6")	508	610	450	160
200 (8")	660	737	525	250
250 (10")	787	838	600	370
300 (12")	914	965	710	630
350 (14")	991	1029	825	850
400 (16")	1092	1130	930	1380
450 (18")	1219	1219	1005	1975
500 (20")	1321	1321	1100	2350

(\*) Dimensions in mm and weight in kg.



# Swing Check Valves Class 900

## Type Pressure Seal

### General Characteristics, Cv, P&T Rating

GENERAL CHARACTERISTICS		Fig. VR900PS			
<b>DESIGN STANDARDS</b>					
Valves design	BS 1868 & API 6D	ASME B16.34	MSS SP- 42		
End to End Dimensions	ASME B16.10 & ISO 5752				
Flanged Dimensions	ASME B16.5 & ISO 7005-1 Part. 1	ASME B16.47	BS 3293	MSS SP-44	
Buttweld Dimensions	ASME B16.25				
Visual Inspection	MSS SP- 55				
Marking	MSS SP-25 & ISO 5209				
<b>TESTS AND CERTIFICATES</b>					
Pressure testing	API 598 & ISO 5208	BS 6755 Part. 1	MSS SP-61		

#### Cv Values in U.S. Gallons/min.

DN	Cv	DN	Cv
50 (2")	100	250 (10")	2200
65 (2½")	170	300 (12")	2900
80 (3")	240	350 (14")	3700
100 (4")	490	400 (16")	6950
125 (5")	670	450 (18")	7950
150 (6")	850	500 (20")	9400
200 (8")	1500		

#### Pressure-Temperature (STANDARD CLASS ACCORDING TO ASME B16.34)

Temp °C	MATERIAL			
	A216 WCB Bar	A352 LCB Bar	A217 C5 Bar	A351 CF8M Bar
-29 to 38	153,0	143,7	155,0	148,8
95	139,5	135,7	154,0	128,2
150	135,7	131,9	148,1	115,8
205	130,9	127,5	145,7	106,1
260	123,7	120,2	137,5	98,9
315	113,0	110,2	125,1	93,4
345	110,9	108,2	121,6	91,6
375	110,2		117,5	89,9
400	104,0		109,2	88,2
425	85,1		105,1	87,2
450	55,5		99,9	86,5
485	35,5		76,5	85,8
510	21,4		56,8	79,9
540	10,7		41,0	72,3
565			29,6 *	71,0 *
595			20,7 *	63,0 *
620			12,7 *	48,9 *
650			7,2 *	38,2 *
675				30,3 *
705				24,1 *
735				20,0 *
760				15,5 *
790				12,1 *
815				8,6 *

\* FOR WELD END VALVES ONLY. FLANGED END RATINGS TERMINATE AT 540°C